

**DIRECTED ENERGY, INC.**  
**PVX-2505**  
**PULSED I-V TEST PULSER**

SERIAL NUMBER: \_\_\_\_\_

DATE: \_\_\_\_\_

Directed Energy, Inc.  
2401 Research Blvd., Ste. 108  
Fort Collins, Colorado 80526  
970/493-1901 FAX 970/493-1903

TABLE OF CONTENTS

1.0 GENERAL DESCRIPTION .....	3
2.0 SPECIFICATIONS .....	4
3.0 SAFETY .....	5
3.1 Operating Safety Summary .....	5
3.1.1 Power Source .....	5
3.1.2 Grounding.....	5
3.1.3 Cover Removal.....	6
3.1.4 General Operating Precautions .....	6
3.2 Servicing Safety Summary .....	6
3.2.1 Servicing Procedure .....	6
3.2.2 Internal Energy Storage.....	6
4.0 OPERATING CONSIDERATIONS.....	7
4.1 Theory of Operation .....	7
4.2 Front Panel Connectors, Switches, and Indicators.....	7
4.3 Rear Panel Connectors .....	8
4.4 Output .....	8
4.5 Pulse Risetime and Falltime .....	9
4.6 Control Pulse Input.....	9
4.7 Power Supply Inputs .....	9
5.0 PREPARATION FOR USE .....	9
5.1 General .....	9
5.2 Initial Inspection .....	10
5.3 Electrical Installation.....	10
5.3.1 Input Power Cord.....	10
5.4 Electrical Check .....	10
5.4.1 Power-Up .....	10
6.0 OPERATING INSTRUCTIONS .....	11
6.1 Power-Up Procedures .....	12
6.2 Power-Down Procedures .....	12
7.0 TROUBLESHOOTING .....	12
7.1 Troubleshooting Procedures .....	12
7.1.1 Fuses.....	14
8.0 SYSTEM FAILURE MODES .....	14
8.1 Over-Current Failure .....	14
8.2 Over-Voltage Failure .....	14
9.0 WARRANTY .....	15

\*\*\*\*\* **WARNING** \*\*\*\*\*

SAFE OPERATING PROCEDURES AND PROPER USE OF THE EQUIPMENT ARE THE RESPONSIBILITY OF THE USER OF THIS SYSTEM.

Directed Energy, Inc (DEI) provides information on its products and associated hazards, but it assumes no responsibility for the after-sale operation and safety practices.

ALL PERSONNEL WHO WORK WITH OR ARE EXPOSED TO THIS EQUIPMENT MUST TAKE PRECAUTIONS TO PROTECT THEMSELVES AGAINST POSSIBLE SERIOUS AND/OR FATAL BODILY INJURY. DO NOT PERFORM INTERNAL REPAIR OR ADJUSTMENTS UNLESS ANOTHER PERSON CAPABLE OF RENDERING FIRST AID AND RESUSCITATION IS PRESENT.

## **1.0 GENERAL DESCRIPTION**

The PVX-2505 pulse generator is designed for pulsed I-V (current-voltage) characterization of semiconductor devices at up to 50 Volts and 10 Amps. It is also well suited for other applications requiring high current, precision voltage pulses.

The I-V characteristics of semiconductor devices are functions of frequency and temperature. Curve tracers and other "DC" test systems typically step through a range of gate voltages and, at each gate voltage, sweep the drain voltage over the measurement range. The device essentially reaches thermal equilibrium and electronic (semiconductor-trap) equilibrium at each point, yielding different test characteristics than actual RF operational characteristics.

By pulsing the device using the PVX-2505 and taking a measurement during the pulse, the measurements can be taken before the device heats up. This circumvents the thermal effects associated with conventional "DC" testing, more closely approximates the characteristics of the device when operating at high frequencies, and doesn't activate the semiconductor "traps".

The PVX-2505 is designed using a bi-directional MOSFET output stage using DEI's DE-Series Fast Power MOSFETs. This design provides fast rise and fall times, with minimal overshoot, undershoot and ringing and fast settling times. This controlled voltage waveform allows the device under test (DUT) to stabilize at voltage within a few hundred nanoseconds, allowing I-V measurements to be made before device heating begins.

A quiescent (bias) voltage may be applied to the pulse generator, allowing the DUT to be held at a voltage other than zero, then pulsed above or below this voltage.

The PVX-2505 requires an input gate signal, pulse (VHIGH) and optional quiescent (VLOW) DC power supply inputs. The output pulse width and frequency are controlled by the input gate signal. The output voltage amplitude is controlled by the amplitude of the input VHIGH and optional VLOW DC power supply amplitudes.

The front panel controls and monitors provide the flexibility to operate in pulsed mode, or to switch to DC mode, in which the DC voltage generated by the VHIGH power supply is applied directly to the DUT. Integral instrument-quality voltage and current probes are provided to facilitate pulse data acquisition.

The output pulse is launched on an innovative, low-impedance cable. The design of this cable maintains the fidelity of the output pulse without

introducing pulse distortion or ringing, and provides a convenient means of connecting the pulse generator to the DUT or bias tee.

The pulse generator is a direct-coupled, air-cooled solid-state design, offering equally fast pulse rise and fall times, low power dissipation, and minimal overshoot, under-shoot or ringing. It has over-current detection and shut-down circuitry to protect the pulse generator from potential damage due to arcs and shorts in the load or interconnect cable.

## **2.0 SPECIFICATIONS**

<b>PULSE (VHIGH) and QUIESCENT (VLOW) PULSE VOLTAGE INPUTS</b>	
Maximum Value	75 volts DC, Floating
Minimum Value	0 volts DC
Input Connector	Screw terminals, Rear Panel
<b>OUTPUT</b>	
Maximum Value	50 volts at 10 A
Minimum Value	0 volts
Maximum Current	10 Amperes
Means of Adjustment	Controlled By Pulse Input Voltage
Pulse Rise Time	<200ns 50V (10%-90%)
Typical Settling Time <sup>(1)</sup>	<400ns, including rise time
Pulse Width	<1 $\mu$ s to 100 $\mu$ s, controlled by input gate
Pulse Recurrence Frequency	Single Shot to 50KHz, controlled by input gate
Maximum Duty Cycle	0.50 (50%)
Output Connector	15 pin D-sub, front panel. Pins 1-8 are pulse return and pins 9-15 are pulse output
<b>MONITOR OUTPUTS</b>	
Voltage Monitor	1V/V into 1M $\Omega$ , accuracy < $\pm$ 3% of the actual output voltage
Voltage Monitor Connector	Type BNC, Front Panel
Current Monitor	0.1V/A into 1M $\Omega$ , accuracy < $\pm$ 3% of the actual output current
Current Monitor Connector	Type BNC, Front Panel

<b>CONTROL PULSE INPUT</b>	
Source	External
Input Level	+5V $\pm$ 1V into 50 $\Omega$
Rise Time	<20ns
Gate Input Connector	Type BNC, Front Panel
<b>GENERAL</b>	
Size	19" (48.25cm) W x 5.2" (13.2cm) H x 13" (33cm) D
Support Power	100-240VAC, 50/60Hz
SPECIFICATIONS SUBJECT TO CHANGE WITHOUT NOTICE	

<sup>(1)</sup> Settling time is defined as the time from the 10% point to the 99% point of the pulse. Pulsed IV data acquisition of both current and voltage waveforms is most optimum when both derivatives are at or near zero. Therefore the data acquisition point should be set beyond the settling time of the pulse.

### **3.0 SAFETY**

Caution should be used when operating or servicing this equipment. The following is a summary of general safety precautions that must be observed during all phases of operation and repair of the PVX-2505.

#### **3.1 Operating Safety Summary**

The safety information contained in this summary is for both operating and servicing personnel. Specific warnings may be found throughout this manual, but may not appear in this summary.

##### **3.1.1 Power Source**

The PVX-2505 is designed to operate from a power source that will not apply more than 240 volts between the supply conductors or between either supply conductor and ground.

A protective grounding connection by way of the grounding conductor in the AC power cord is essential.

##### **3.1.2 Grounding**

The PVX-2505 is grounded through the grounding conductor of the AC power cord. **To avoid electrical shock, plug the PVX-2505 into a properly wired receptacle before making connection to any input or output connectors.** Use only a power cord that is in good condition.

### 3.1.3 Cover Removal

To avoid personal injury, do not remove the covers. **Do not operate the PVX-2505 while the covers are removed.** The covers do not contain a safety interlock!

### 3.1.4 General Operating Precautions

Do not remove the input or output cables while the pulser is in operation. Failure to observe these precautions can result in potential electric shock to personnel, arcing, and damage to the connectors and system.

The top cover of the PVX-2505 is not safety interlocked. Extreme caution should be exercised when removing the cover.

Any pulsed power system is capable of random triggering via transients. Therefore when the PVX-2505 is turned on, or voltage is present in the chassis, assume it is possible to get a pulse on the output connector.

## 3.2 Servicing Safety Summary

The PVX-2505 contains dangerous voltages and stored energy. DEI strongly recommends that all repairs and adjustments be performed by factory qualified personnel. DEI will not be responsible for personal injury or damage to the driver that occurs during repair by any party other than the factory.

### 3.2.1 Servicing Procedure

Do not perform internal repair or adjustments unless another person capable of rendering first aid and resuscitation is present.

### 3.2.2 Internal Energy Storage

The PVX-2505 contains capacitors that are used as energy storage elements. When charged to 75 Volts, these capacitors contain approximately 5 Joules of stored energy. This is sufficient energy to cause serious injury. **Assure that the AC power cord is disconnected from the driver, and that the capacitor bank is fully discharged before any repairs or adjustments are attempted.** Verify with a voltmeter that all circuits are de-energized before servicing. The voltmeter used to make these measurements must be certified for use at 500VDC and 220VAC or greater. Dangerous voltages, floating ground planes and energy storage exist at several locations in the PVX-2505. Touching connections and/or components could result in serious injury.

## **4.0 OPERATING CONSIDERATIONS**

### **4.1 Theory of Operation**

A functional schematic diagram of the PVX-2505 pulser is shown in Figure 1. The switching elements are power MOSFETs. Current is sensed with the  $0.2\ \Omega$  resistors. Voltage is sensed directly, and buffered and terminated with a  $50\ \Omega$  resistor. The control logic on the board receives the "PULSE IN", "POLARITY", AND "DC/PULSE" signals from switches and a BNC connector on the front panel. The logic circuitry then processes these signals to derive the floating gate signals for the power MOSFETs.

The  $V_{HIGH}$  and  $V_{LOW}$  inputs must always be positive because of the polarized electrolytic capacitors used for energy storage. The  $V_{HIGH}$  input must always be greater than or equal to the  $V_{LOW}$  input in magnitude because of the intrinsic diodes in the power MOSFETs.

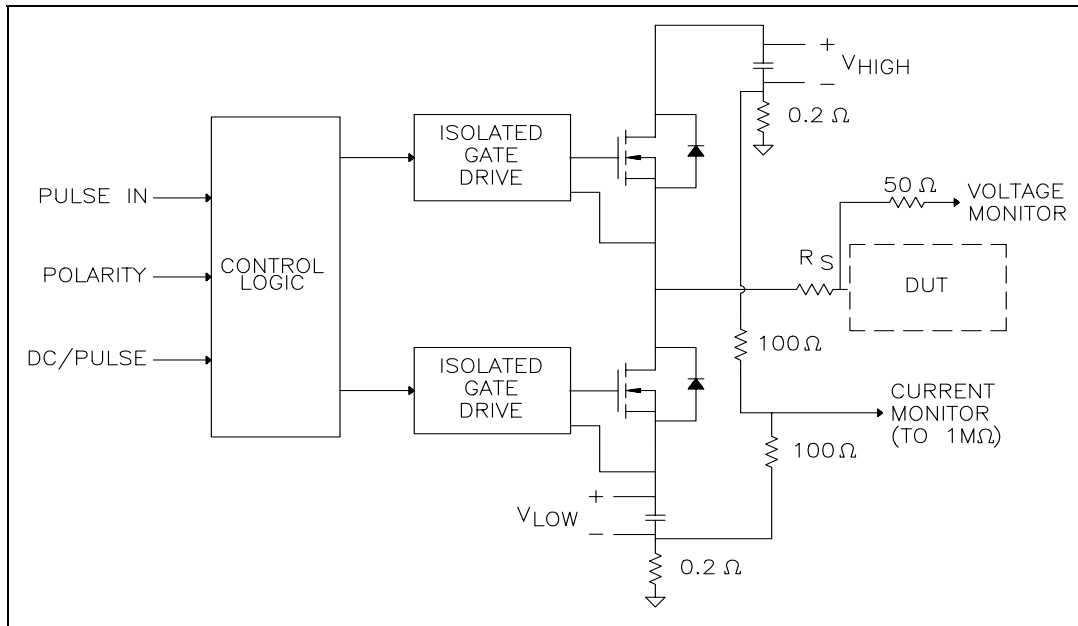

**Figure 1. PVX-2505 Pulser functional schematic diagram**

### **4.2 Front Panel Connectors, Switches, and Indicators**

**LINE Switch** - This switch controls AC power into the unit.

**LINE LED** - This LED indicates that AC power to the unit is turned on.

**CONTROL PULSE IN** - This BNC connector provides an input for the 5V pulse which controls the pulser. It is terminated internally in  $50\ \Omega$ .

**POLARITY Switch** - This switch controls the polarity of the logic signal. When in the POS position, the unit pulses in the positive direction when the CONTROL PULSE IN signal is at 5V. When in the NEG position, the unit pulses in the negative direction when the CONTROL PULSE IN signal is at 5V.

**MODE Switch** - This switch disables the CONTROL PULSE IN signal when in the DC position and allows pulsed operation when in the PULSE position.

**POLARITY and MODE LEDs** - The POLARITY and MODE LEDs simply show what position the respective switches are in.

**VOLTAGE MONITOR** - This BNC connector provides a current monitor signal for viewing with a 1 M $\Omega$  oscilloscope input. It is scaled at 1 V/V.

**CURRENT MONITOR** - This BNC connector provides a current monitor signal for viewing with a 1 M $\Omega$  oscilloscope input. It is scaled at 0.1 V/A.

**OUTPUT** - This 15 pin D-sub connector provides the pulse output from the unit. Pins 1 - 8 are ground and pins 9 - 15 are the signal. This connector allows connection to low-impedance output cable.

**AUX OUT** - The AUX OUT 1 and AUX OUT 2 output connectors are feed throughs from the AUX IN 1 and AUX IN 2 input connectors on the rear panel.

#### 4.3 Rear Panel Connectors

**POWER SUPPLY INPUTS** - This terminal strip provides screw terminals for +, -, and Ground connections for the V<sub>HIGH</sub> and V<sub>LOW</sub> power supplies.

**CAUTION: The power supplies must be FLOATING.**

**LINE INPUT** - This IEC connector provides a standard chassis mounted connection for the AC line input, as well as housing the fuses and line voltage selection switch.

**RF LOGIC PULSE** - The RF Logic Pulse input accepts an external RF logic input, and generates a TTL level replica and complement (Q and Q-Bar). The TTL level output connectors are terminated into 50 $\Omega$ .

**AUX IN** - The AUX IN 1 and AUX IN 2 input connectors are feed throughs to the AUX OUT 1 and AUX OUT 2 output connectors on the front panel.

#### 4.4 Output

The PVX-2505 is designed to operate into a load which will draw up to 10 Amps. An improperly terminated output will cause excessive aberrations on

the output waveform and could possibly damage the driver. To ensure this does not occur, observe the following precautions:

- Make all external connections tight and as short as possible;
- Ensure that all external cables and hardware have adequate voltage and power ratings.

#### 4.5 Pulse Risetime and Falltime

The physical and electrical characteristics of the cable transmitting the pulse determine the characteristic impedance, velocity of propagation and the amount of signal loss. Several feet of cable can attenuate high frequency components of the pulse. It is therefore important to keep these cables as short as is practical. For optimum performance, DEI recommends interconnecting cable lengths of 2' or less.

#### 4.6 Control Pulse Input

An input of +5V  $\pm$ 1V into 50 $\Omega$  with a risetime of <20ns is required for the control pulse input of the PVX-2505. Departure from these values can result in a loss of performance. These requirements are met by any high quality low voltage pulse generator. The control pulse should be set to +5V  $\pm$ 1V into 50 $\Omega$  before the cable is attached to the PVX-2505 control pulse input. The input trigger amplitude should be set using a 50 $\Omega$  load (e.g. a 50 $\Omega$  scope input) before connecting it to the PVX-2505. If the input is greater than +5V into 50 $\Omega$ , pulse stretching can occur.

#### 4.7 Power Supply Inputs

The PVX-2505 is rated at a maximum  $V_{HIGH}$  and  $V_{LOW}$  voltage of 75VDC. Proper precautions should be taken by the user to ensure that the maximum voltage is not exceeded.

### **5.0 PREPARATION FOR USE**

#### 5.1 General

After unpacking, initial inspection and preliminary electrical check procedures should be performed to assure that the unit is in good working order. If it is determined that the unit is damaged, the carrier should be notified immediately. Repair problems should be directed to the service department, Directed Energy, Inc. (DEI), Fort Collins, Colorado. Telephone: (970) 493-1901.

## 5.2 Initial Inspection

1. Inspect unit for exterior mechanical damage.
2. Inspect power input cord and input power module for obvious signs of damage.

## 5.3 Electrical Installation

Standard units are shipped ready for use with a nominal 120 VAC input.

### 5.3.1 Input Power Cord

The input power cord terminates externally in a three-prong polarized plug. The unit chassis is wired to the plug through the line cord, and therefore, the insertion of the plug into a compatible receptacle, hooked up to a grounded input, will automatically ground the unit. The unit should not be operated without a grounded AC input!

## 5.4 Electrical Check

Before proceeding, please review the precautions in Section 3.

### 5.4.1 Power-Up

The unit should be powered up using the following procedures:

1. Ensure that the  $V_{HIGH}$  and  $V_{LOW}$  supplies are turned off, and all controls set to zero volts.
2. Set the "MODE" switch to the "PULSE" position. Set the "POLARITY" switch to the "POS" position. The respective amber LEDs should be lit.
3. Before connecting the pulse generator to the PVX-2505, set up the pulse generator output to deliver a +5V pulse ( $\pm 1V$ ) into  $50\Omega$ , with a rep rate of approximately 500Hz, and a pulse width of  $10\mu s$ .
4. Plug the power cord into the AC power input and put the line switch in the "1" position. The "LINE" indicator light should turn on, indicating that the PVX-2505 is operational. If this does not occur, unplug the unit from the AC power, and refer to the Troubleshooting Section of this manual.
5. Connect the cable from the  $V_{HIGH}$  power supply to the terminal strip on the rear panel of the PVX-2505 labeled " $V_{HIGH}$ ".
6. Connect the pulse generator to the front panel BNC connector of the PVX-2505 labeled "CONTROL PULSE IN".

7. Ensure that no load is connected to the front panel D-sub connector of the PVX-2505 labeled "OUTPUT". (So that the unit is operating open-circuit).
8. Connect the cable from the  $V_{LOW}$  supply to the terminal strip on the rear panel of the PVX-2505 labeled " $V_{LOW}$ ".
9. Monitor the voltage at the output, by connecting the VOLTAGE MONITOR BNC to a 1 M $\Omega$  oscilloscope input, utilizing an appropriate setting on the oscilloscope.
10. Turn ON the  $V_{HIGH}$  power supply. Slowly increase the voltage to 10VDC. The PVX-2505 should produce an output pulse of approximately 10V, with a pulse width and pulse recurrence frequency following that of the incoming trigger.
11. If there is no output from the PVX-2505, or the output is severely distorted, set the output voltage of the  $V_{HIGH}$  power supply to zero and turn off the pulse voltage power supply. Leave the PVX-2505 connected to the AC input without pulse voltage and with all connectors in place for approximately five minutes to bleed off the stored energy, then disconnect the AC power to the unit and refer to the Troubleshooting Section of this manual.

## **6.0 OPERATING INSTRUCTIONS**

This section provides basic operating instructions for the PVX-2505.

### **WARNING**

1. To avoid personal injury, do not remove the covers. Do not operate the PVX-2505 while the covers are removed. The covers do not contain safety interlocks!
2. Do not remove the input or output cables while the driver is in operation. Never short-circuit the pulse voltage output of the pulser. Failure to observe these precautions can result in potential electric shock to personnel, arcing, and damage to the connectors and system.
3. The covers of the PVX-2505 are not safety interlocked. Extreme caution should be exercised when removing the covers.
4. Pulsed power systems are capable of random triggering via transients and therefore when the PVX-2505 is turned on, or voltage is present in the chassis, assume it is possible to get a pulse on the output connector.

## 6.1 Power-Up Procedures

The unit should be powered up using the procedures detailed in Section 5.4.1. When this is accomplished, the driver can be adjusted for the particular application through the following procedure:

1. Monitoring the output of the PVX-2505 on an oscilloscope utilizing the built-in voltage and current sensors, set the output amplitude of the PVX-2505 to the desired level by adjusting the pulse voltage power supply.
2. Set the output pulse width and pulse recurrence frequency by varying the controls of the input pulse generator. The output pulse width should be set by monitoring the output of the PVX-2505. The output pulse voltage will follow the input trigger, but will not replicate in time the exact duration of the input trigger due to asymmetrical propagation delays.

## 6.2 Power-Down Procedures

1. Set the output voltage of the pulse voltage power supply to zero and turn off the pulse voltage power supply.
2. Disconnect the AC power to the unit.

## 7.0 TROUBLESHOOTING

### WARNING

The PVX-2505 contains capacitors that are used as energy storage elements. When charged to 75 Volts, these capacitors contain approximately 5 Joules of stored energy. This is sufficient energy to cause serious injury. **Assure that the AC power cord is disconnected from the driver, and that the capacitor bank is fully discharged and a shorting strap installed before any repairs or adjustments are attempted.** Verify with a voltmeter that all circuits are de-energized before servicing. The voltmeter used to make these measurements must be certified for use at 500VDC and 220VAC or greater. Dangerous voltages, floating ground planes and energy storage exist at several locations in the PVX-2505. Touching connections or components could result in serious injury.

## 7.1 Troubleshooting Procedures

Before attempting to service or troubleshoot the PVX-2505, review the servicing safety summary in Section 3.0.

The DEI DE-Series power MOSFETs utilized in the PVX-2505 are mounted on the printed circuit board. In the unlikely event that the MOSFETs need be

replaced, it is highly recommended that the unit be returned to the factory for servicing.

The table below summarizes potential problems and their solutions. If these recommendations do not resolve the problem, DEI customer service can be contacted for further assistance.

<b>SYMPTOM</b>	<b>SOLUTIONS</b>
"LINE" LED Does Not Illuminate	<ul style="list-style-type: none"><li>• AC power not plugged in</li><li>• Fuse(s) are blown. See fuse replacement instructions in Section 8.1.1</li><li>• No input trigger</li><li>• Mode Switch in DC Position</li><li>• Input trigger voltage too low</li><li>• Input trigger pulse width too short. Increase width</li><li>• Input trigger frequency too high. Reduce frequency</li><li>• No input pulse voltage. Check pulse supply and connections</li><li>• Output not connected correctly. Check all cables and connections</li><li>• Driver is damaged. Contact DEI customer service</li></ul>
No Output Pulse	

### 7.1.1 Fuses

To avoid fire hazard or damage to the driver, use only fuse values indicated on the rear panel silkscreen. Fuse replacement should be performed by qualified personnel only. **Assure that the AC power cord is disconnected from the driver before fuse replacement is attempted.**

The fuses are located in the power entry module on the rear panel.

## **8.0 SYSTEM FAILURE MODES**

### 8.1 Over-Current Failure

When the output is shorted, the PVX-2505 can deliver in excess of 10A of current (depending on cabling, pulse power supply setting, etc.). A current pulse of this magnitude is in excess of the driver's specifications. If allowed to operate at greater than rated current for an extended period of time, damage to the unit, load and/or associated cabling may result.

### 8.2 Over-Voltage Failure

Input voltages in excess of 75V may damage the PVX-2505. It is the user's responsibility to ensure that this maximum input is never exceeded.

## **9.0 WARRANTY**

Directed Energy, Inc. (DEI) warrants equipment it manufactures to be free from defects in materials and factory workmanship under conditions of normal use, and agrees to repair or replace any standard product that fails to perform as specified within one year after date of shipment to the original owner. OEM, modified and custom products are warranted, as stated above, for ninety (90) days from date of shipment to the original owner. This Warranty shall not apply to any product that has been:

- I. Repaired, worked on, or altered by persons unauthorized by DEI in such a manner as to injure, in DEI's sole judgement, the performance, stability, or reliability of the product;
- II. Subjected to misuse, negligence or accident; or
- III. Connected, installed, adjusted, or used otherwise than in accordance with instructions furnished by DEI.

DEI reserves the right to make any changes in the design or construction of its products at any time, without incurring any obligation to make any change whatever in units previously delivered.

DEI's sole obligation, and buyer's sole remedies, under this agreement shall be limited to a refund of the purchase price, or at DEI's sole discretion, to the repair or replacement of products in kind that prove, to DEI's satisfaction, to be defective, when returned to the DEI factory, transportation prepaid by the buyer, within the warranty period. DEI shall in no way be liable for damages consequential or incidental to defects in its products, for failure of delivery in whole or in part, for injuries resulting from its use, or for any other cause.

Returns must be preauthorized and accompanied by a DEI return authorization number.

The foregoing states the entire warranty extended by DEI, and is given and accepted in lieu of 1) any and all other warranties, expressed or implied, including by not limited to the implied warranties of merchantability and fitness for any particular purpose and 2) any obligation, liability, right, claim or remedy in contract or tort.