



**DIRECTED ENERGY, INC.**

**PVM-4140**  
**±3,000V Pulse Generator Module**  
**OPERATION MANUAL**

Directed Energy, Inc.  
An IXYS Company  
2401 Research Blvd., Ste. 108  
Fort Collins, Colorado 80526  
970/493-1901 FAX 970/493-1903

## Table Of Contents

1.0 Safety .....	3
2.0 Overview .....	3
3.0 Specifications .....	5
4.0 Connector Pin-Outs And User Adjustments .....	6
5.0 OPERATING INSTRUCTIONS .....	7
5.1 Output Cabling.....	7
5.2 Load Interconnection .....	7
5.3 Gate Input.....	8
5.4 Pulse Voltages +V IN and -V IN .....	8
5.5 Output Pulse Considerations .....	8
5.6 Operation With Common +HV In and -HV In Polarities .....	9
5.7 Interlock Input.....	10
5.8 Enable / Disable / Reset Input .....	10
5.9 System Faults.....	11
5.10 Power-Up Procedures .....	12
5.11 Power-Down Procedures.....	13
6.0 TROUBLESHOOTING .....	14
6.1 Troubleshooting Procedures.....	14
6.2 Factory Service.....	14
7.0 WARRANTY .....	15
APPENDIX .....	16
Mechanical Dimensions And Mounting Hole/Connector Location Drawing	16

\*\*\*\*\* **WARNING** \*\*\*\*\*

SAFE OPERATING PROCEDURES AND PROPER USE OF  
THE EQUIPMENT ARE THE RESPONSIBILITY OF THE  
USER OF THIS SYSTEM.

Directed Energy, Inc (DEI) provides information on its  
products and associated hazards, but it assumes no  
responsibility for the after-sale operation and safety  
practices.

ALL PERSONNEL WHO WORK WITH OR ARE EXPOSED  
TO THIS EQUIPMENT MUST TAKE PRECAUTIONS TO  
PROTECT THEMSELVES AGAINST POSSIBLE SERIOUS  
AND/OR FATAL BODILY INJURY.

## **1.0 Safety**

The high voltage/high current nature of this device dictates the use of caution when operating or servicing this equipment. OBSERVE ALL SAFETY PRECAUTIONS LISTED BELOW. FAILURE TO DO SO COULD RESULT IN SERIOUS INJURY.

Precautions:

1. The Pulser should be serviced only by personnel experienced in high voltage pulsed power systems.
2. Service personnel should be instructed to observe all safety precautions as stated in the operating instructions, and those safety precautions standard to the high voltage pulsed power community. Failure to do so could result in serious injury.
3. Do not handle the load or terminations, or remove the input or output cables, while the driver is in operation. Ensure that the high voltage power supplies have fully discharged before handling the load. Failure to observe these precautions can result in potential electric shock to personnel, arcing, and damage to the connectors and system.
4. The Pulser contains reference planes which are elevated to the potential of the output pulse. Extreme caution should be exercised when servicing the equipment.
5. Pulsed power systems are capable of random triggering via transients and therefore when the driver is turned on, or high voltage is present in the module, assume it is possible to get a pulse on the output cable.

## **2.0 Overview**

The PVM-4140 is a compact, OEM-style pulse generator module producing fast, high voltage waveforms to 3,000V. Optimized for driving high impedance capacitive loads, the PVM-4140 is well suited for driving extraction grids and deflection plates for electrostatic modulation of particle beams in time-of-flight mass spectrometers and accelerators. Its robust and versatile design also makes it well suited for pulsing or gating power tube grids, Pockels cells and Q Switches, acoustic transducers, microchannel plates, photomultiplier tubes and image intensifiers.

The PVM-4140 will generate an output voltage pulse of 3000 volts with rise and fall times less than 25ns, with very flat voltage pulses to DC into a capacitive load. It can generate singled-ended output pulses from ground to +3000V or from ground to -3000V. It can also generate pulses originating from a DC voltage offset from ground by using both VLow and VHigh power supply inputs.

The PVM-4140 requires user-supplied +24VDC to +28VDC support power, a TTL gate signal, a high voltage DC power supply and optional DC offset supply inputs. The output pulse width and frequency are controlled by the gate signal. The amplitude of the input DC power supplies controls the pulse output voltage.

The pulser is a half-bridge (totem pole) design, offering equally fast pulse rise and fall times, low power dissipation, and virtually no over-shoot, under-shoot or ringing. The PVM-4140 has over-current detection and shut-down circuitry to protect the pulse generator from potential damage due to arcs and shorts in the load or interconnect cable.

The PVM-4140 incorporates all control and protection logic circuitry, energy storage and output network. It can be connected directly to the load, and does not require series or shunt resistors, impedance-matching networks between the pulser and the load, or additional energy storage (capacitor banks). The pulser is housed in an aluminum enclosure, with threaded mounting holes in the base to simplify installation and assembly in OEM applications.

The PVM-4140 pulser is a direct-coupled, all solid-state design using air as the primary insulating medium. Its conservative design margin gives you long component life. And keeping the PVM-4140 free of potting compound or encapsulation materials makes it easy to service if a component ever does require replacement.

The block diagram below shows the main functional blocks of the pulser:

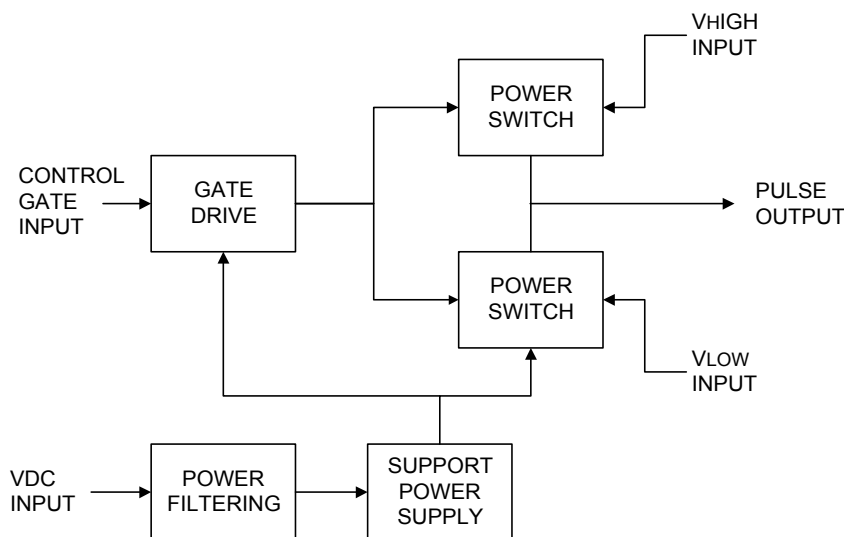

***PVM-4140 Functional Block Diagram***

### 3.0 Specifications

The pulser will meet or exceed the following specifications. All specifications are measured into a 50pF load connected with 2 feet" (~60cm) of 75Ω RG-59 coaxial cable:

<b>OUTPUT</b>	
Maximum Value:	±1500 Volts ( $V_{High} - V_{Low}$ )
Minimum Value:	0 Volts
Means Of Adjustment:	Controlled By Power Supply Input Voltages
Pulse Rise And Fall Time:	<25ns (10% to 90%)
Pulse Width:	<60ns (typically 55ns) to DC, Controlled by Input Gate
Pulse Recurrence Frequency (PRF):	Single shot to >25KHz at 3000V output, 300kHz maximum limited by power dissipation <sup>(1)</sup> , 5MHz Burst, Controlled by Input Gate
Max. Average Power:	50W ( $V_{High} + V_{Low}$ ) <sup>(1)</sup>
Max. Duty Cycle:	Continuous
Droop:	<1%
Over/undershoot:	<5%
Throughput Delay	120ns Typical
Jitter:	<200ps shot-to-shot
Output Connector:	SHV, with 2 feet (~61cm) RG-59 (75Ω) Coaxial Cable
Output Cable:	RG-59 (75Ω) Coaxial Cable, 2 feet (~61cm) long
<b>INPUT DC VOLTAGE +HV<sub>IN</sub> (<math>V_{High}</math>)</b>	
Absolute Max. Value:	+3000 Volts
Absolute Min. Value:	-3000 Volts
Relative Max. Value:	+3000 Volts over $V_{Low}$ Voltage
Relative Min. Value:	+0V Over $V_{Low}$ Voltage
Input Connector:	SHV, End Panel
<b>INPUT DC VOLTAGE -HV<sub>IN</sub> (<math>V_{Low}</math>)</b>	
Absolute Max. Value:	+3000 Volts
Absolute Min. Value:	-3000 Volts
Input Connector:	SHV, End Panel
<b>GATE</b>	
Gate Source:	External
Gate Input:	TTL into 50Ω
Connector:	BNC or DB-15 Pin 2, End Panel
<b>GENERAL</b>	
Support Power:	+24VDC To +28VDC @ 250mA Maximum Current
Dimensions (Excluding Connectors):	9.8" W x 10.2" L x 2" H (249mm W x 259mm L x 51mm H)
Weight (Approximate):	56 Ounces (1.13 Kilograms)
SPECIFICATIONS SUBJECT TO CHANGE WITHOUT NOTICE	

These specifications are measured driving a 50pF load connected with 2 feet of RG-59 cable, at 3000V output. However the PVM-4140 can drive loads of a few picofarads to several hundred picofarads of capacitance, limited by its maximum power dissipation capability<sup>(1)</sup>. At lower load capacitances and/or voltages less than 3000V, the PVM-4140 can operate at continuous pulse recurrence frequencies up to

500kHz. The PVM-4140 can also drive resistive or inductive loads, within limitations. Contact DEI for additional information and applications assistance.

<sup>(1)</sup>The power dissipated in the PVM-4140 when driving a capacitive load is defined by the formula  $CV^2F$ , where C is the total load capacitance, including the capacitance of the load, interconnect cable, and the internal capacitance of the PVM-4140, V is the pulse voltage, and F is the pulse repetition frequency (or the total pulses per second). (For these calculations, the internal capacitance of the PVM-4140 is 120pF, and RG-59 cable is 21.5pf/foot.) Given the maximum dissipation of 50W, the maximum load capacitance, frequency and/or voltage at which the PVM-4140 can operate can be approximated using this formula. This formula also approximates the high voltage power supply requirements needed to drive a given load at a specific voltage and frequency. This formula is not applicable when driving resistive or inductive loads.

## **4.0 Connector Pin-Outs And User Adjustments**

### **Input And Output Connectors:**

DB-15 PIN Number	Function
P1 – 1	Interlock Input (Low = OK)
P1 – 2	Gate Input (TTL into 50Ω) In parallel with Gate BNC connector
P1 - 3	Enable/Disable/Reset Input (Momentary Low)
P1 - 4	Fault Output (High = Fault)
P1 - 5	Invert (Low = internally inverts the output)
P1 - 6	Output Enabled (High = notifies that output is enabled)
P1 - 7	Auto Reset (Low = To enable auto reset)
P1 - 8	+24VDC to +28VDC @ 200mA Maximum Input
P1 - 14	N/C
P1 - 9 Through 15	Ground

**Pulse Out:** Pulse Output (SHV Connector, End Panel). Should be connected to load with RG-59 75 Ohm coaxial cable or equivalent

**+ HV In:** -3000VDC to +3000VDC input. Must be greater than - HV In. (SHV Connector, End Panel)

**- HV In:** -3000VDC to +3000VDC input. Must be less than - HV In. (SHV Connector, End Panel)

**Gate:** The input gate that controls the output pulse width and frequency. The gate may be input either to the Gate BNC connector, or to pin 2 of the DB-15 connector. Do NOT use both gate inputs simultaneously. Only one of the gate inputs may be connected at one time.

If the INVERT pin is pulled low, the gate pulse going in to the unit will become inverted internally. Therefore, the output pulse will be inverted from that of the input gate. If the user is using the INTERLOCK pin, it should be pulled low to satisfy the interlock.

Otherwise, it should be jumpered to pin 9. The AUTORESET function allows the user to choose how to clear the faults. If the AUTORESET pin is pulled low, the unit will reset itself after 6msec when a fault occurs such as an overcurrent or interlock fault. If the AUTORESET is not pulled low, the user will have to reset faults manually.

## **5.0 OPERATING INSTRUCTIONS**

### **WARNING**

1. Do not remove the input or output cables while the pulser is in operation. Never intentionally short-circuit the high voltage output of the pulser. Failure to observe these precautions can result in potential electric shock to personnel, arcing, and damage to the connectors and system.
2. Pulsed power systems are capable of random triggering via transients and therefore when the pulse generator is turned on, or high voltage is present in the chassis, assume it is possible to get a pulse on the output connector.

### **5.1 Output Cabling**

The PVM-4140 is designed to drive capacitive loads with fast rise times. Since the current out of the PVM-4140 is limited, the lower the capacitance, the faster the risetime. Given fixed load characteristics, only the interconnecting cable type and length will vary the output capacitance.

The unit is supplied with a 2 foot length of RG-59 coaxial cable which has a capacitance of 21.5pF per foot. The unit is series terminated in the characteristic impedance of this cable, which is 75Ω. DEI recommends that the shortest length of cable possible be used to ensure the fastest possible rise times and best pulse fidelity. Only 75Ω coaxial cable should be used to connect the output of the pulse generator to the load.

### **5.2 Load Interconnection**

The load should be connected using only 75Ω coaxial cable (RG-59 or equivalent). Any inductance introduced into the circuit through the use of wire interconnections, or impedance mismatches caused by using cable with an impedance other than 75Ω, may causing ringing on the output pulse, or a general degradation of waveform fidelity. For optimal waveform fidelity, the ends of the coaxial cable should be connected directly to the load to minimize interconnection inductance and impedance mismatches. If it is necessary to use wire leads between the coaxial cable and the load, the leads should be kept as short as possible. Twisting the leads together (i.e. using a twisted pair) will reduce the lead inductance and help to preserve waveform fidelity.

### 5.3 Gate Input

An input gate of  $+5V \pm 1V$  into  $50\Omega$  with a risetime of  $<20ns$  is required to gate on the PVM-4140. Departure from these values can result in a loss of performance. These trigger requirements are met by any high quality low voltage pulse generator. The trigger should be set to  $+5V \pm 1V$  into  $50\Omega$  before the trigger cable is attached to the PVM-4140 gate input. The input gate amplitude should be set using a  $50\Omega$  load (e.g. a  $50\Omega$  scope input) before connecting it to the PVM-4140. If the gate input is greater than  $+5V$  into  $50\Omega$ , pulse stretching can occur. The gate may be input either to the Gate BNC connector, or to pin 2 of the DB-15 connector. Do NOT use both gate inputs simultaneously. Only one of the gate inputs may be connected at one time.

### 5.4 Pulse Voltages +V IN and -V IN

The PVM-4140 Pulser is rated at a maximum pulse output voltage of  $\pm 3000VDC$ . Proper precautions should be taken by the user to ensure that the maximum voltage is not exceeded.

### 5.5 Output Pulse Considerations

The PVM-4140 Pulser can generate single-ended output pulses from ground to  $+3000V$  or from ground to  $-3000V$ , and can also generate pulses originating from a voltage offset from ground. This offset can be from  $-3000V$  to  $+3000V$ , but the maximum power supply voltage differential ( $V_{high} - V_{low}$ ) should never exceed  $3000V$ . The  $V_{high}$  supply should always be equal to or greater than the  $V_{low}$  supply, but never greater than  $3000V$  above the  $V_{low}$  supply. Therefore the  $V_{low}$  supply may be set to any voltage between  $-3000V$  and  $+3000V$ , and the  $V_{high}$  supply may be set to any voltage between  $-3000V$  and  $+3000V$ , but the voltage difference between  $V_{low}$  and  $V_{high}$  should never exceed  $+3000V$ . If the unit is operated with a single power supply (i.e. single-ended), the unused power supply input should be grounded.

When the input gate is high, the  $V_{high}$  supply is connected to the output. When the input gate is low, the  $V_{low}$  supply is connected to the output. Therefore the PVM-4140 can be used to generate a negative-going pulse by logically inverting the input gate, so that the input gate is high until the unit is pulsed. When the input gate goes low, the  $V_{low}$  supply is connected to the output, thereby generating a negative going pulse (see the example in the figure below).

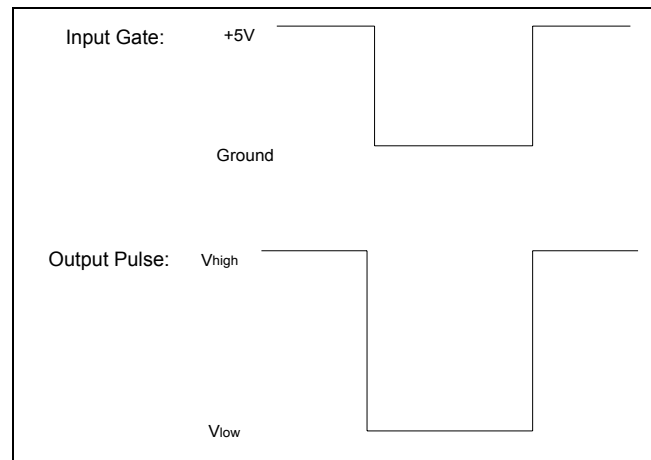

Generating a Negative Pulse With The PVM-4140

### 5.6 Operation With Common +HV In and -HV In Polarities

The PVM-4140 may be operated with the +HV and -HV inputs at a common polarity (i.e. -HV In at +500V and +HV In at +1500V, or -HV In at -1000V and +HV In at -500V).

However most high voltage DC power supplies cannot regulate voltages of the same polarity from a separate source. Positive power supplies sink (draw) electrons from ground, while negative power supplies source (push) electrons to ground. To operate with power supplies of common polarity, the lower voltage ( $V_{LOW}$ ) supply (i.e. -HV In) must be provided with an additional current flow path to ground. If this path is not provided, the output voltage may not remain at the -HV In potential when the PVM-4140 is not gated, but can be charged up to the potential of the  $V_{HIGH}$  (+HV In) supply due to leakage current within the PVM-4140. This is often observed if the load does not draw current, or as the PVM-4140's pulse repetition frequency is increased.

The path to ground can be accomplished with a shunt resistor (i.e. a resistor from the -HV In power supply input to ground) in low power applications, or with an active shunt regulator for high power applications. To determine the best method for a particular application, three things must be known:

1. The maximum pulse repetition frequency;
2. The maximum differential voltage ( $V_{HIGH} - V_{LOW}$ );
3. Total load capacitance (including the load, interconnect cable, and strays)

The formula  $CV^2F$  (where C is the total load capacitance, V is the differential voltage, and F is the pulse repetition frequency) will provide the minimum power that must be dissipated in the resistor or shunt regulator from switching the

capacitive load. In addition, DC current from the  $V_{LOW}$  DC supply will flow in the shunt resistor. This power can be calculated by the formula:

$$\frac{V^2}{R}$$

Where  $V$  is the  $V_{LOW}$  voltage, and  $R$  is the resistance of the shunt resistor. Therefore the total power ( $P_{TOTAL}$ ) dissipated in the shunt resistor is:

$$C(V_{HI} - V_{LOW})^2 F + \frac{(V_{LOW})^2}{R}$$

The value of the shunt resistor can be approximated using the formula:

$$R = \frac{(V_{LOW})^2}{P_{TOTAL}}$$

The  $V_{LOW}$  (-HV In) DC power supply must be able to provide the power, and the  $V_{HIGH}$  (+HV In) DC power supply must be able to provide the  $CV^2F$  power.

$$\frac{(V_{LOW})^2}{R}$$

Please note that this potential problem does not occur if the input DC power supplies are of different polarities (i.e. -HV in at -1000V and +HV In at +500V), or if one of the DC supply inputs is grounded (i.e. -HV In is connected to ground and +HV In is at +3000V. Furthermore, depending on the DC power supply used, at low pulse repetition rates with small capacitive loads, this problem may not be observed because of the small internal paths to ground found within the DC power supply.

### 5.7 Interlock Input

The PVM-4140 provides an external interlock input. This interlock must be held low in order to enable the pulse generator. The interlock can be wired to a switch, or pulled to ground through a relay, transistor or through computer control.

If the interlock is opened, the output of the PVM-4140 will be disabled, and a fault set. After the interlock is satisfied (pulled low), the fault must be reset and the PVM-4140 enabled using the procedures detailed in Sections 5.8 and 5.9.

### 5.8 Enable / Disable / Reset Input

The Enable/Disable/Reset input requires a momentary switch closure. This can be done using a mechanical momentary switch, a relay, a transistor or a computer interface.

The Enable/Disable/Reset input is used to enable or disable the output of the PVM-4140. Its use is described below:

- On Power Up: The PVM-4140 powers up in a Fault status. To enable the unit, momentarily close the Enable/Disable/Reset input twice, once to clear the fault status, and again to enable the output. If there are no fault conditions, the PVM-4140 will enable, and output pulses will be generated.
- To Disable The Output: After the output is enabled, momentarily closing the Enable/Disable/Reset input will disable the output.

**WARNING: Disabling the output inhibits the control logic from generating output pulses, however the internal capacitor banks are not discharged, and high voltage may be present in the system. Do not remove the input or output cables or handle the load while the pulser is disabled. Follow the power-down procedures in the Section 5.11 before removing the input or output cables or handling the load. Pulsed power systems are capable of random triggering via transients and therefore when the pulse generator is turned on, or high voltage is present in the chassis, assume it is possible to get a pulse on the output connector.**

- To Reset A Fault: The PVM-4140 will set a fault for an over-current condition, or if the interlock is broken. When a fault is set, the fault output (DB-15 Pin 4) goes high, and the output is disabled. To reset the fault, momentarily close the Enable/Disable/Reset input, then momentarily close it again to re-enable the output.

## 5.9 System Faults

The PVM-4140 will set a fault if an output over-current condition is detected, or if the external interlock is broken. When a fault is set, the fault output goes high, and the output is disabled.

An over-current condition is generated when the output current exceeds approximately 25A for a 300ns duration. This is usually caused by the following conditions:

- The load or output cable is shorted or arcing;
- The impedance of the load is too low;
- The capacitance of the load is too high;
- The load is too inductive.

The PVM-4140 should not be operated continuously into a load that causes an over-current condition. If an over-current fault occurs, the reason for the fault should be corrected. For assistance in using the PVM-4140 with inductive or resistive loads, or for driving loads with a large capacitance, contact DEI.

If the external interlock is opened, it must be closed before the fault can be reset, and the unit enabled.

To reset a fault, momentarily close the Enable/Disable/Reset input, then momentarily close it again to re-enable the output.

The PVM-4140 can be configured, through an internal jumper setting, to automatically clear the fault and reset the unit when a fault is encountered. This operating mode allows the PVM-4140 to clear a fault and continue operating without user intervention, however in the case of a shorted load or an arc in the cable or load, continued operation in this mode may eventually damage the load or interconnect cable. Contact DEI for additional information on configuring the PVM-4140 for auto-reset mode.

### 5.10 Power-Up Procedures

1. The unit should be powered up using the following procedures:
2. Before connecting the input TTL pulse generator to the PVM-4140 pulser, set up the pulse generator output to deliver a TTL level pulse into 50 ohms, with a repetition rate <5KHz, and a pulse width greater than 100ns.
3. Connect an appropriate load to the end panel SHV output connector.
4. Connect the input DSUB connector prior to applying +24VDC power.
5. Connect the positive output power supply to the end panel SHV connector labeled +HV IN. Connect the negative output power supply to the rear panel SHV connector labeled -HV IN. For +3000V single-ended output, -HV IN must be connected to ground. The power supply input should be grounded if no power supply is connected. Ensure that both power supplies are turned off.
6. Apply +24VDC to +28VDC power to the module.
7. Connect the pulse generator to the end panel BNC connector of the PVM-4140 labeled "GATE", or to pin 2 of the DB-15 connector.
8. Close the external interlock input.
9. Enable the PVM-4140 by toggling (i.e. applying a momentary switch closure) twice to the enable line (DB-15 Pin 3), once to clear the power-on fault, and once to enable the PVM-4140.
10. Monitor the voltage at the output, by connecting an appropriate high voltage probe to the output load, utilizing an appropriate attenuator if necessary.
11. Slowly turn up the high voltage power supplies. The PVM-4140 should produce an output pulse, with a pulse width and pulse recurrence frequency following that of the incoming trigger.
12. If there is no output from the PVM-4140, or the output is severely distorted, turn OFF the high voltage power supplies. Leave the PVM-4140 connected to

the DC input support power without pulse voltage and with all connectors in place for approximately one minute to bleed off the stored energy, then disconnect the DC power to the unit and refer to the Troubleshooting Section of this manual.

### 5.11 Power-Down Procedures

1. Set the controls of the high voltage power supplies to zero.
2. Turn off the high voltage power supplies.
3. Leave the PVM-4140 connected to the +24VDC input without high voltage and with all connectors in place for approximately one minute to bleed off the stored energy.
4. Disconnect the DC support power to the unit.

## **6.0 TROUBLESHOOTING**

### **WARNING**

The module contains capacitors that are used as energy storage elements. When charged, these capacitors contain in excess of 0.02 joules of stored energy. This is sufficient energy to cause injury. Assure that the +24VDC power is disconnected from the pulser, and that the capacitor bank is fully discharged and a shorting strap installed before any repairs or adjustments are attempted. Verify with a voltmeter that all circuits are de-energized before servicing. Dangerous voltages, floating ground planes and energy storage exist at several locations in the module. Touching connections or components could result in serious injury.

### **6.1 Troubleshooting Procedures**

The table below summarizes potential problems and their solutions. If these recommendations do not resolve the problem, DEI customer service can be contacted for further assistance.

#### **SYMPTOM**

#### **SOLUTIONS**

1. No output pulse.

- No input trigger.
- Input trigger voltage too low.
- Input trigger pulse width too short. Increase width.
- Input trigger frequency too high. Reduce frequency.
- No input high voltage. Check HV supplies.
- Enable circuit not satisfied.
- Fault Condition - Check Fault output.
- Output not connected correctly. Check all cables and connections.
- Pulser is damaged. Contact DEI customer service.

### **6.2 Factory Service**

If the procedures above fail to resolve an operational problem, please contact the factory for further assistance:

DIRECTED ENERGY, INC.  
2401 RESEARCH BLVD SUITE 108  
FORT COLLINS, CO 80526  
(970) 493-1901 FAX (970) 493-1903

## **7.0 WARRANTY**

There are no warranties, express or implied, including any implied warranty of fitness for a particular purpose nor any IMPLIED WARRANTY OF MERCHANTABILITY made by Directed Energy, Inc. (DEI) except as follows:

DEI warrants equipment manufactured by it to be free from defects in materials and/or workmanship under conditions of normal use for a period of one year from the date of shipment to the purchaser. DEI will repair or replace, at DEI's option, any product manufactured by it which is shown to be defective or fails to perform within specifications within one year from the date of shipment to the purchaser. OEM, modified and custom items of equipment are similarly warranted, for a period of ninety (90) days from date of shipment to the purchaser.

Equipment claimed to be defective must be returned, transportation prepaid, to DEI's factory in Fort Collins, Colorado within the warranty period. Returns must be preauthorized by contact with DEI's customer service department. Written documentation of such preauthorization shall be included with the returned item.

At DEI's discretion, DEI may elect to repair or replace the equipment claimed to be defective or refund the original purchase price, plus taxes and transportation charges incurred by the purchaser.

This Warranty shall not apply to any product that has been:

1. Repaired, worked on, or altered by persons unauthorized by DEI;
2. Subjected to misuse, neglect, or damage by others; or
3. Connected, installed, adjusted, or used in a manner not authorized in the instructions or specifications furnished by DEI.

This warranty is the purchaser's sole remedy for claimed defects in the equipment sold or manufactured by DEI. DEI's liability to the purchaser is limited to the repair or replacement of the claimed defective equipment or, at DEI's option, refund of the purchase price, taxes and transportation charges incurred by the purchaser. DEI will not be responsible for or liable to the purchaser for consequential losses or damages asserted to be attributable to a claimed defect in the equipment provided.

Changes made by DEI in the design or manufacture of similar equipment which are effected subsequent to the date of shipment of the warranted equipment to the purchaser are reflective of DEI's program of constant product development and improvement and shall not be construed as an acknowledgement of deficiency in the product shipped to purchaser. DEI will be under no obligation to make any changes to product previously shipped.

**APPENDIX**

Mechanical Dimensions And Mounting Hole/Connector Location Drawing

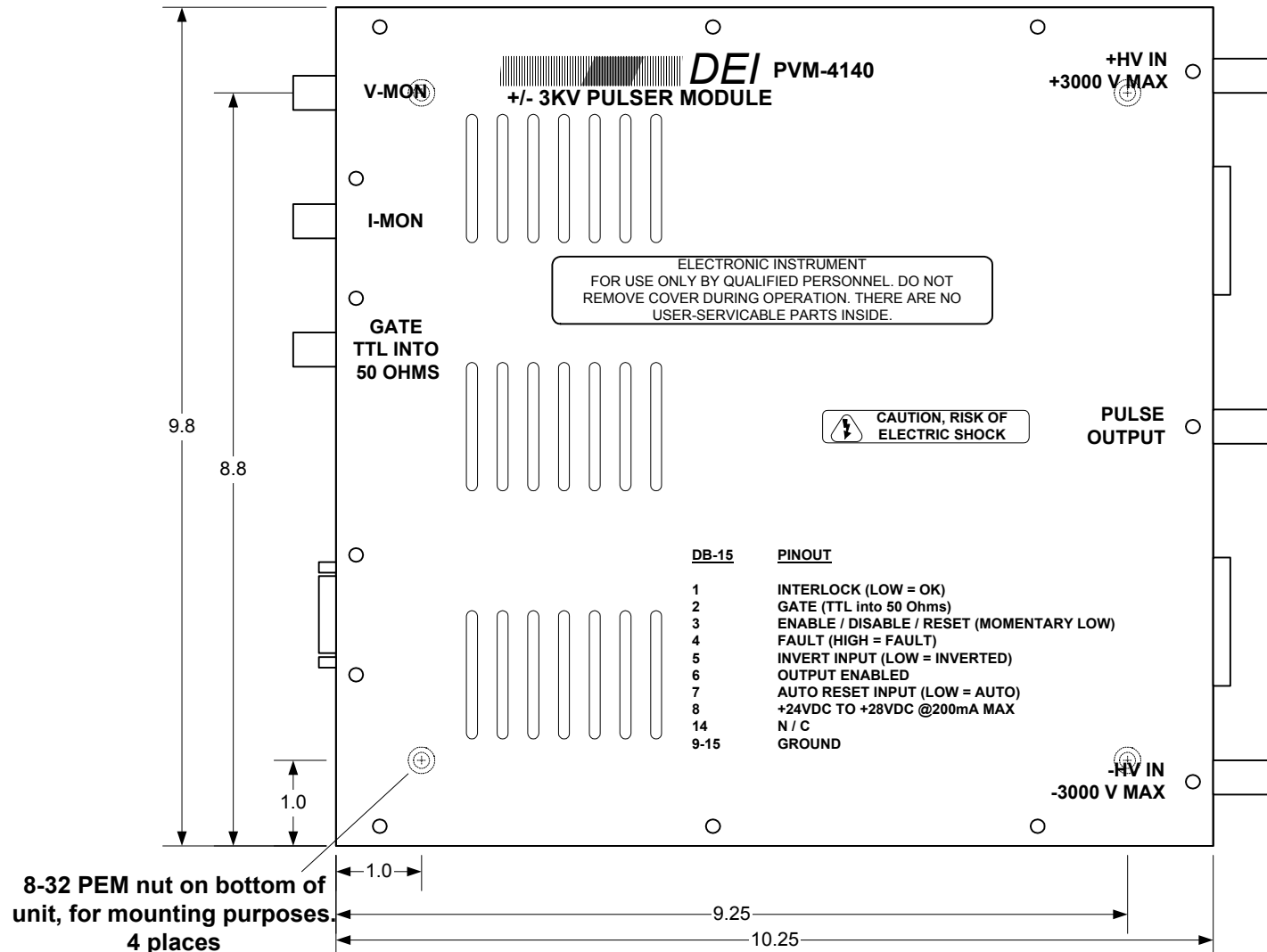

*PVM-4140 Mechanical Dimensions And Mounting Hole/Connector Locations  
 Not to scale. All dimensions are in inches*